



**SPLIT TYPE
ROOM AIR CONDITIONER
CEILING WALL type
INVERTER**

**SERVICE
MANUAL**



Models

Indoor unit	Outdoor unit
AWHZ14LBC	AOHZ14LBC
AWHZ18LBC	AOHZ18LBC

CONTENTS

SPECIFICATIONS.....	1
OUTLINE AND DIMENSIONS.....	2
REFRIGERANT SYSTEM DIAGRAM	3
CIRCUIT DIAGRAM.....	4
INDOOR PCB CIRCUIT DIAGRAM	5
OUTDOOR PCB CIRCUIT DIAGRAM . . .	8
ERROR CONTENTS.....	10
DISASSEMBLY ILLUSTRATION	11
PARTS LIST.....	14



Большая библиотека технической документации

<https://splitsystema48.ru/instrukcii-po-ekspluatácii-kondicionerov.html>

каталоги, инструкции, сервисные мануалы, схемы.

SPECIFICATIONS

TYPE	Cooling and Heat-pump heating	
INDOOR UNIT	AWHZ14LBC	AWHZ18LBC
OUTDOOR UNIT	AOHZ14LBC	AOHZ18LBC
COOLING CAPACITY	4.2 kW	5.2 kW
HEATING CAPACITY	6.0 kW	6.7 kW

ELECTRICAL DATA

POWER SUPPLY		230 V 50 Hz	
RUNNING CURRENT	COOLING	4.5 A	6.9 A
	HEATING	5.9 A	7.2 A
INPUT WATTS	COOLING	1.02 kW	1.58 kW
	HEATING	1.35 kW	1.63 kW
E.E.R.	COOLING	4.12 kW/kW	3.29 kW/kW
	HEATING	4.44 kW/kW	4.11 kW/kW
MOISTURE REMOVAL		2.1 L/hr	2.8 L/hr
AIR CIRCULATION-HIGH	COOLING	850 m3/hr	
	HEATING	940 m3/hr	

COMPRESSOR

TYPE	Hermetic type, Inverter, Three phase Induction motor, Rotary		
DISCRIMINATION	808 - 907 - 80		
REFRIGERANT	R410A	1,350 g	

FAN MOTOR

POWER SOURCE		230 V	
INDOOR UNIT (cool / heat)	HIGH2	1,550 r.p.m. / 1,750 r.p.m.	
	HIGH-SPEED	1,450 r.p.m. / 1,650 r.p.m.	
	MED-SPEED	1,320 r.p.m. / 1,350 r.p.m.	
	LOW-SPEED	1,050 r.p.m. / 1,150 r.p.m.	
	QUIET	880 r.p.m. / 1,000 r.p.m.	
	SUPER-QUIET	730 r.p.m. / 820 r.p.m.	
OUTDOOR UNIT (cool / heat)	HIGH2	835 / 820 r.p.m.	850 / 900 r.p.m.
	HIGH-SPEED	820 / 730 r.p.m.	820 / 730 r.p.m.

DIMENSIONS and WEIGHT

INDOOR UNIT	H x W x D	250 x 899 x 298 mm
OUTDOOR UNIT	H x W x D	578 x 790 x 300 mm
INDOOR UNIT	GROSS / NET	17 kg / 13.5 kg
OUTDOOR UNIT	GROSS / NET	43 kg / 39 kg

NOISE LEVEL

INDOOR UNIT (cool / heat)	HIGH2	47 dB / 47 dB	47 dB / 47 dB
	HIGH-SPEED	46 dB / 46 dB	46 dB / 46 dB
	MED-SPEED	43 dB / 39 dB	43 dB / 39 dB
	LOW-SPEED	35 dB / 34 dB	35 dB / 34 dB
	QUIET	29 dB / 29 dB	29 dB / 29 dB
	SUPER QUIET	24 dB / 24 dB	24 dB / 24 dB
OUTDOOR UNIT (cool / heat)	HIGH2	47 dB / 49 dB	48 dB / 50 dB
	HIGH-SPEED	46 dB / 47 dB	47 dB / 48 dB

Note : Noise was measured in accordance with JIS standards, Japan.

"HIGH2" means when ability measurement

REFRIGERANT CHARGE (R410A)

FULL CHARGE AMOUNT	Pipe Length 15 m	1,350 g
	20 m	1,450 g
ADDITIONAL REFRIGERANT		20 g / m
MAX PIPE LENGTH		20 m

DIMENSIONS

Models :
AWHZ14LBC, AWHZ18LBC

(Unit : mm)

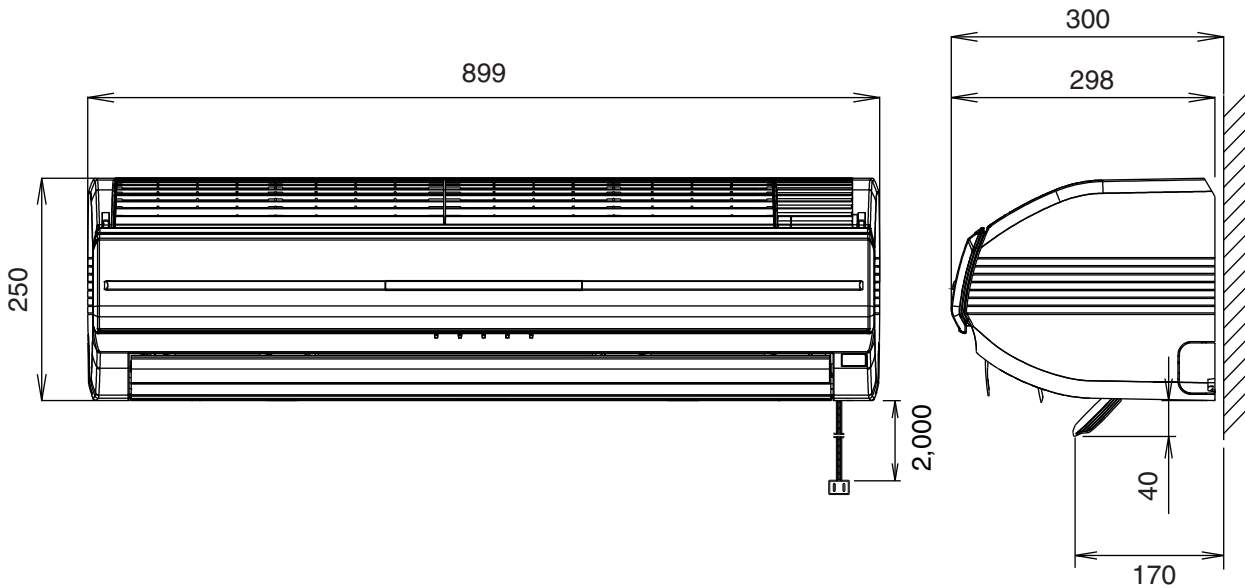

Models :
AOHZ14LBC, AOHZ18LBC

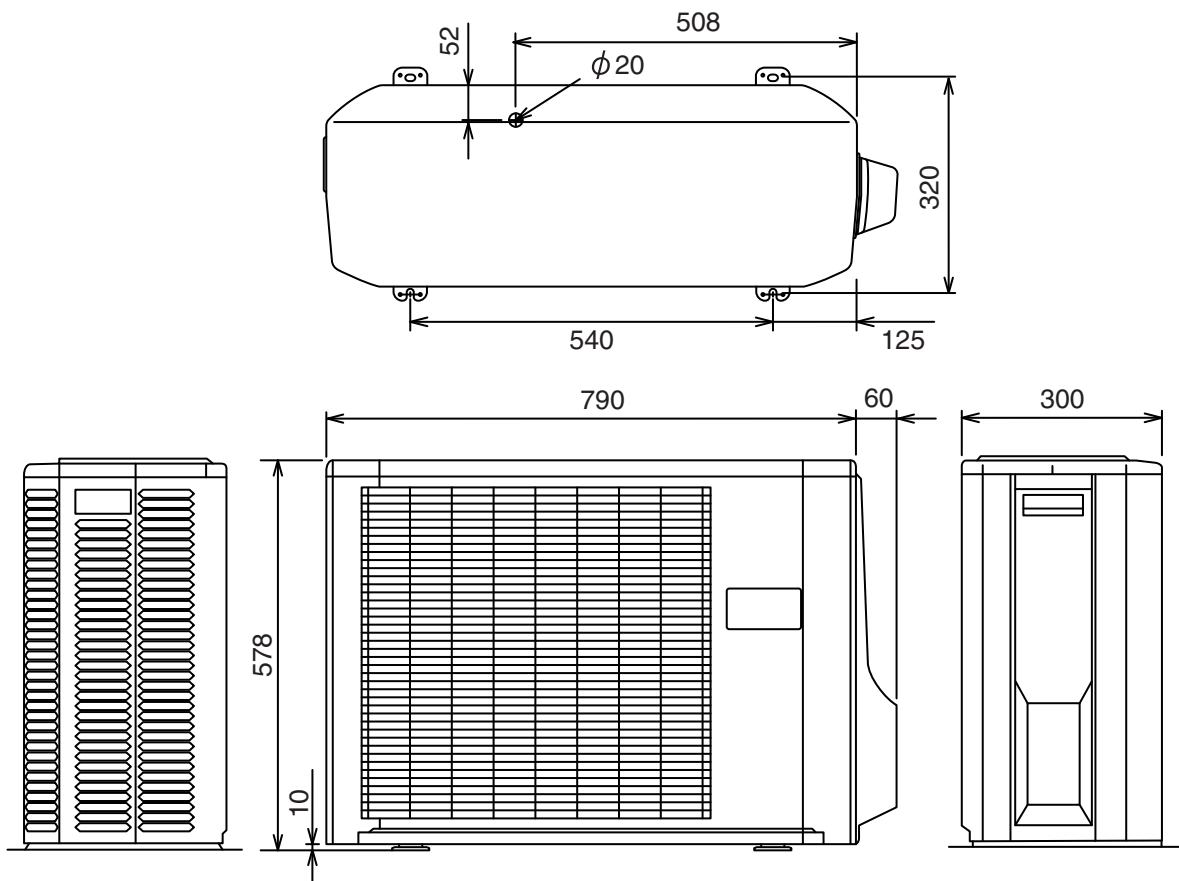



REFRIGERANT SYSTEM DIAGRAM

Models :

AWHZ14LBC / AOHZ14LBC

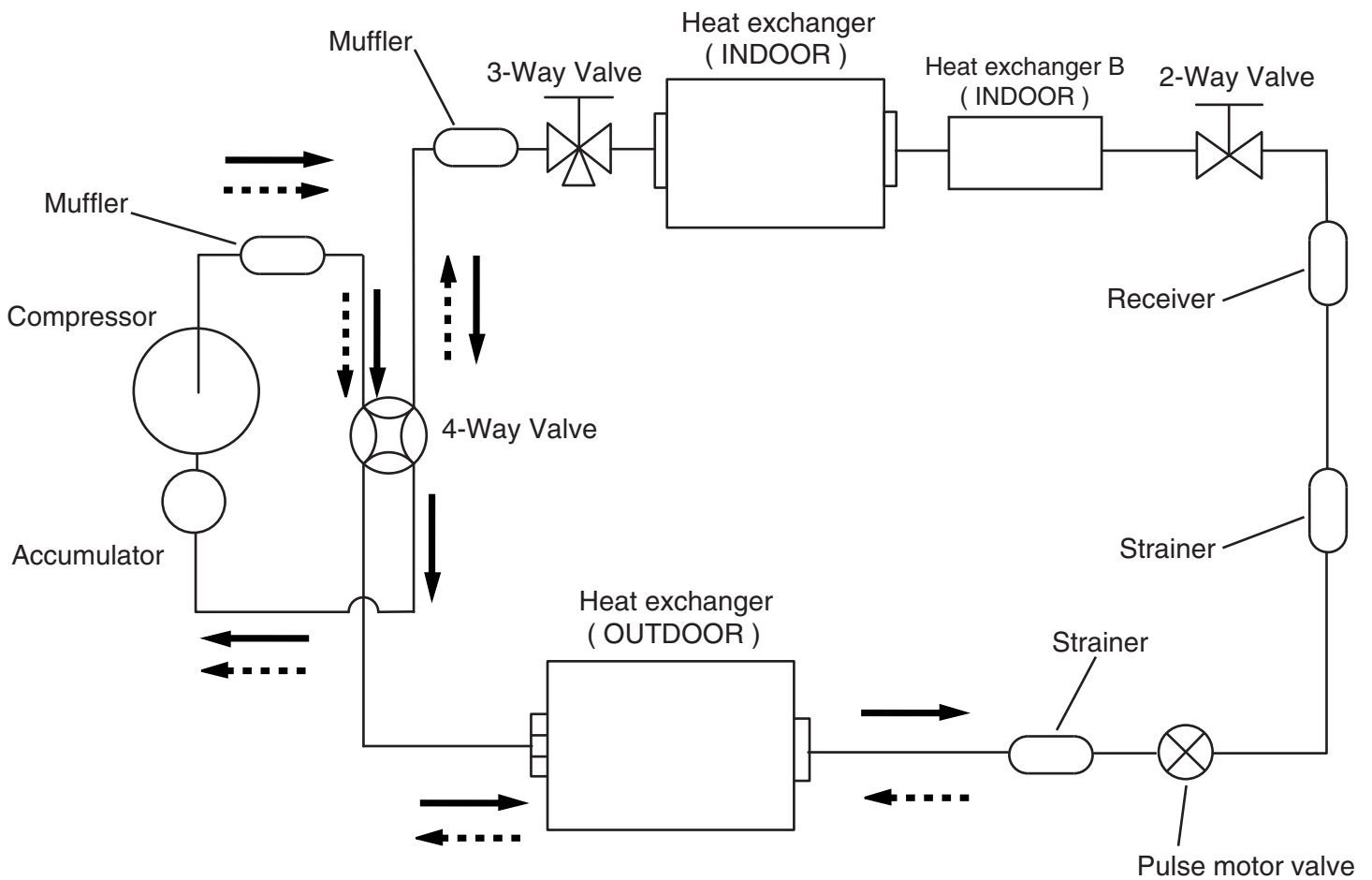
AWHZ18LBC / AOHZ18LBC



 Cooling
 Heating

Liquid pipe : 6.35 mm

Gas pipe : 12.7 mm

CIRCUIT DIAGRAM

INDOOR UNIT

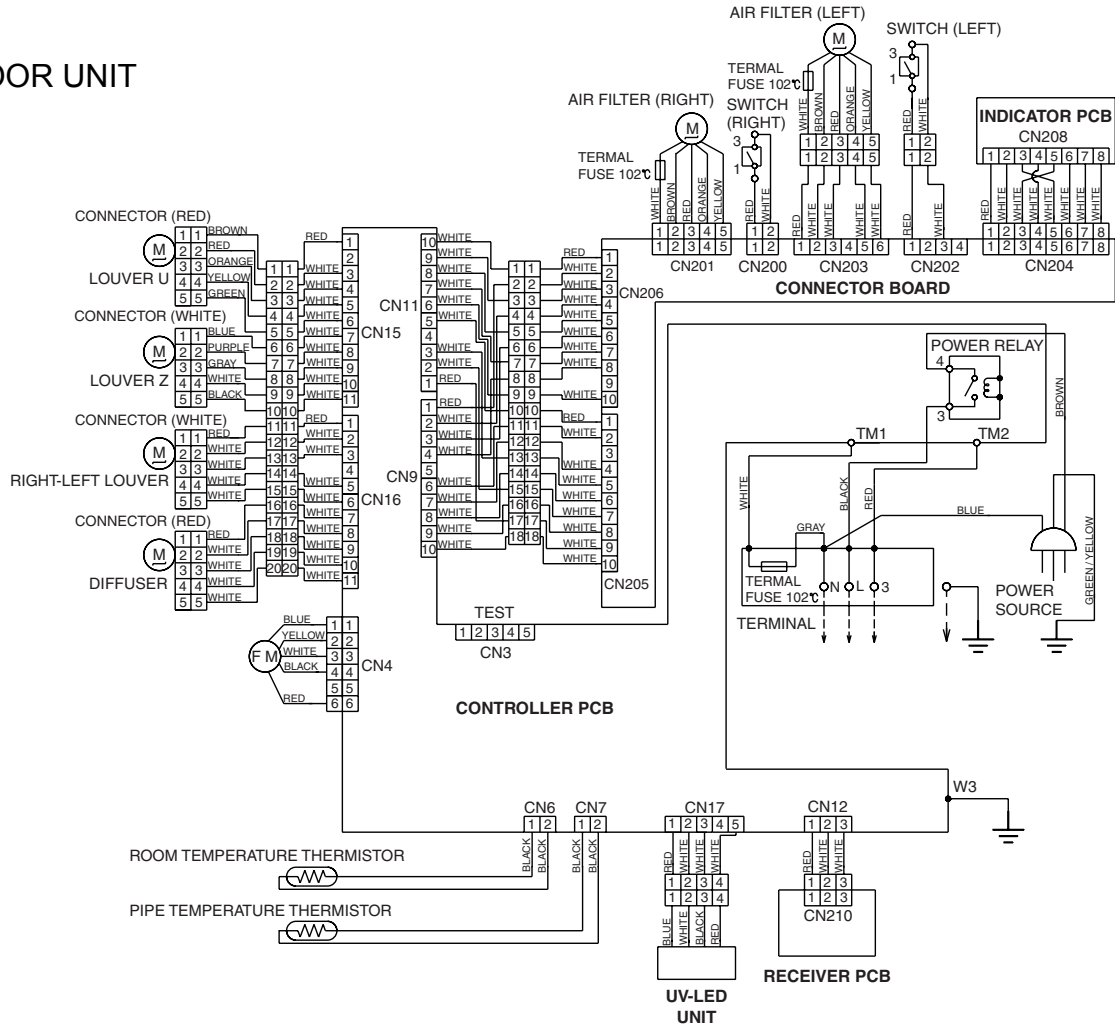

OUTDOOR UNIT

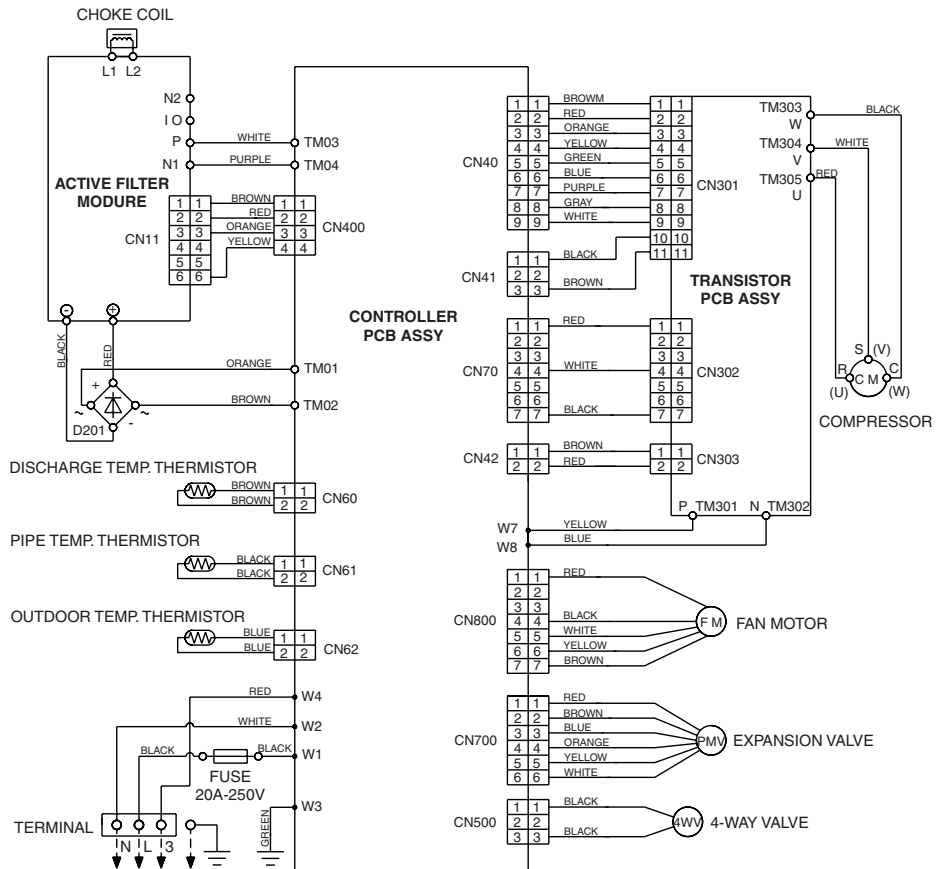

INDOOR PCB CIRCUIT DIAGRAM

Models : AWHZ14LBC
AWHZ18LBC

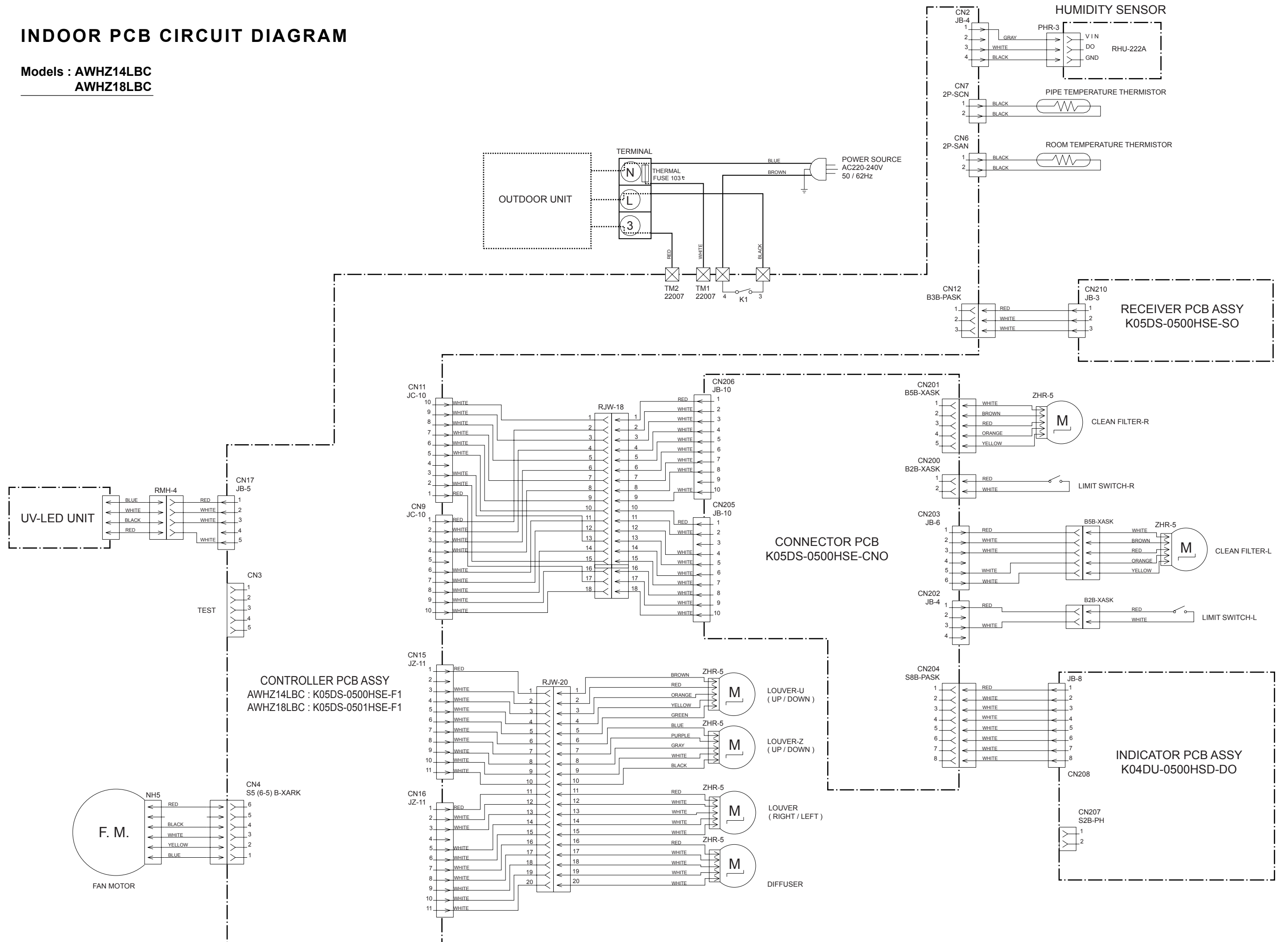

Models : AWHZ14LBC
AWHZ18LBC

CONTROLLER PCB ASSY
AWHZ14LBC : K05DS-0500HSE-F1
AWHZ18LBC : K05DS-0501HSE-F1

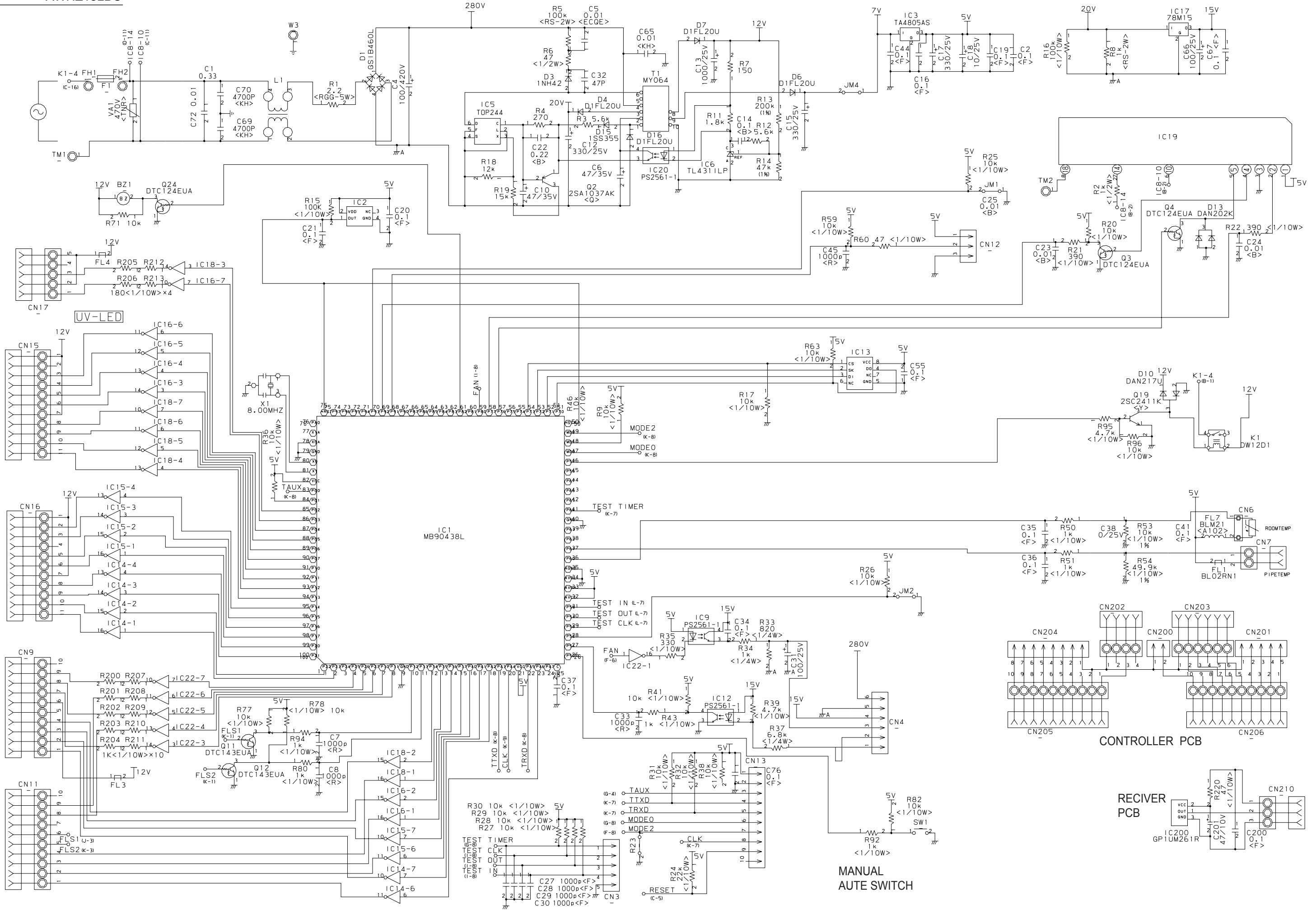

INDICATOR PCB

Models : AWHZ14LBC
AWHZ18LBC

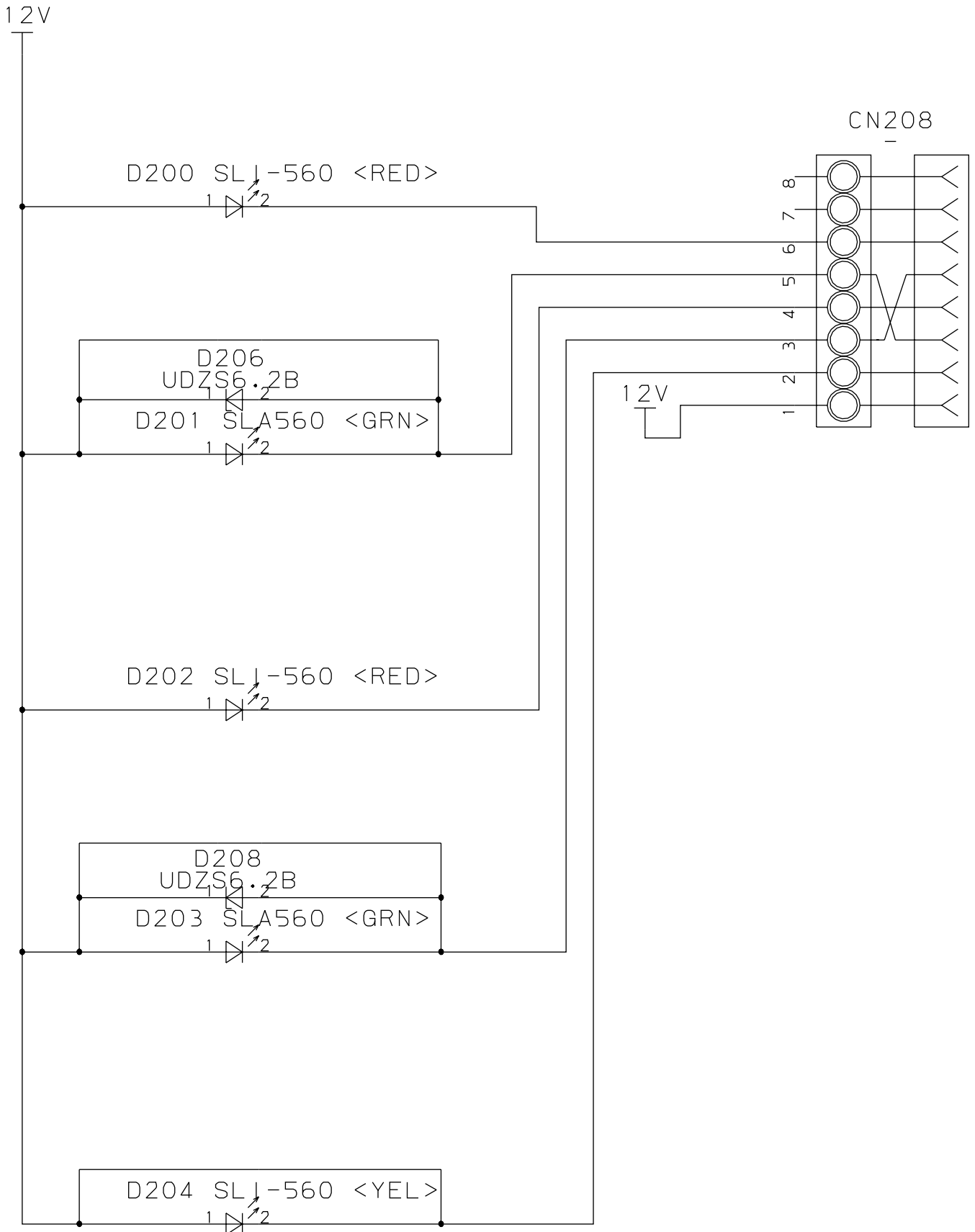

OUTDOOR PCB CIRCUIT DIAGRAM

Models : AOHZ14LBC
AOHZ18LBC

INVERTER ASSEMBLY
AOHZ14LBC : EZ005CHUE
AOHZ18LBC : EZ005DHUE

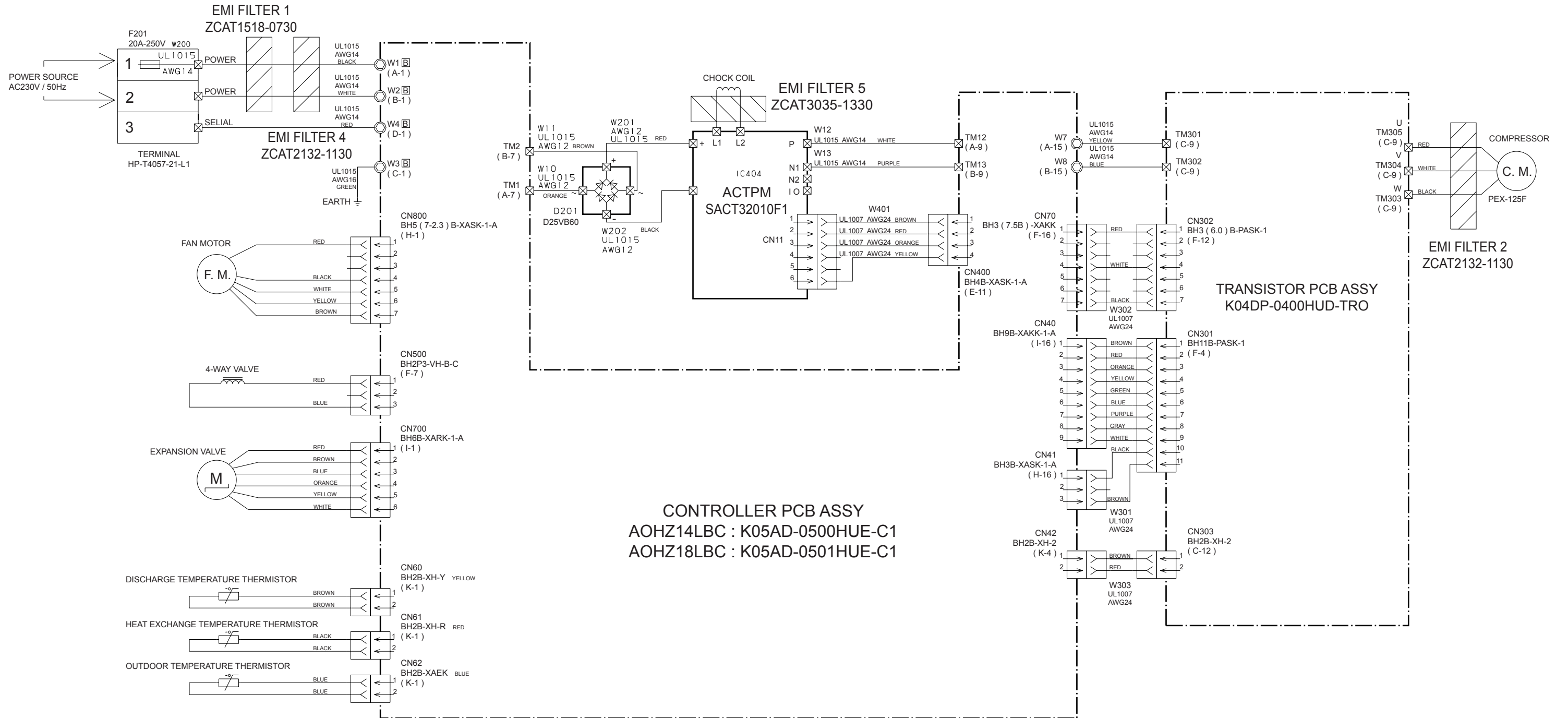

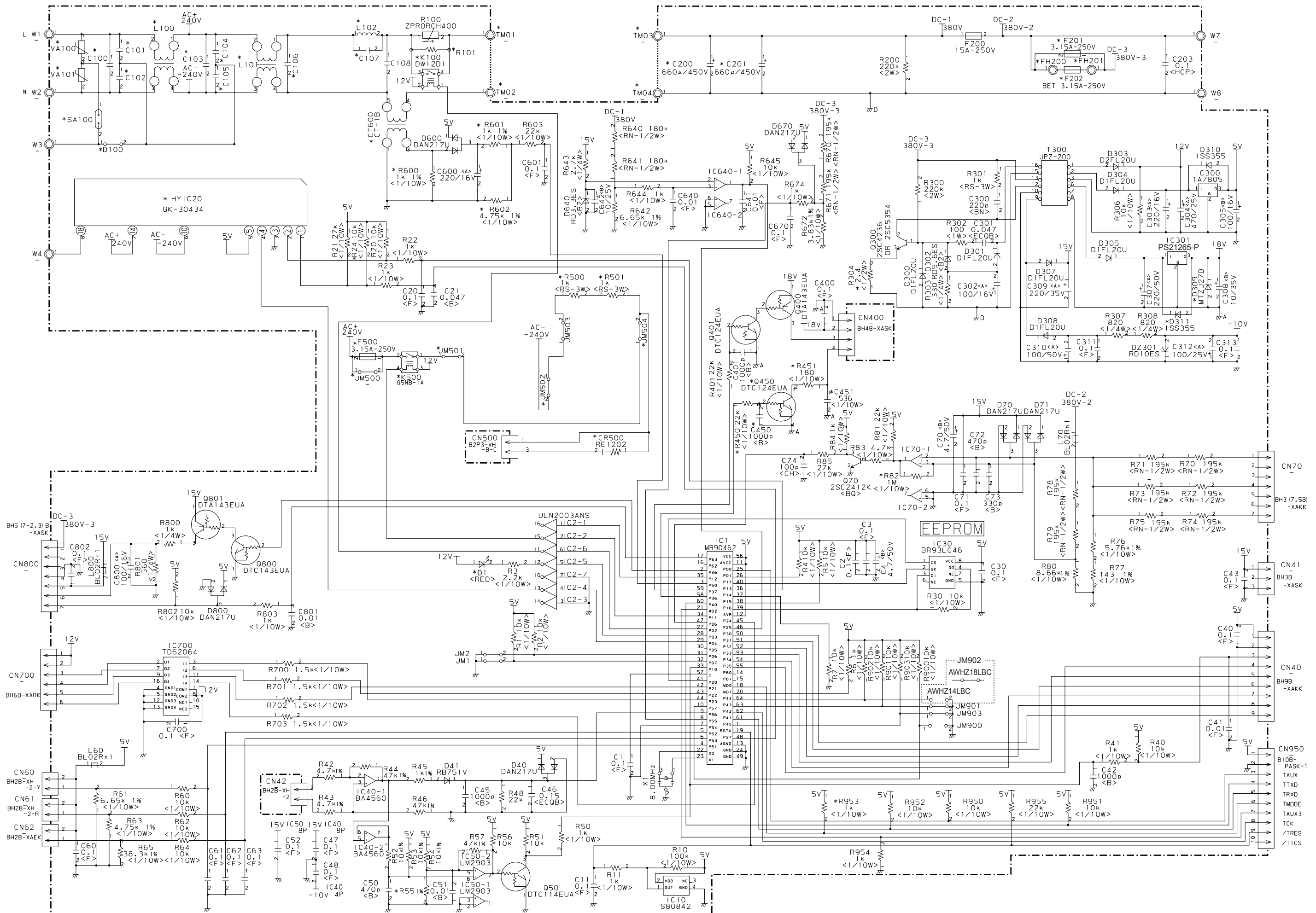

ERROR CONTENTS

Error	Display		Error
	Operation LED	Timer LED	
Serial signal error	Off	2 flash	Serial signal (reverse) error, at operation start up
		3 flash	Serial signal (reverse) error, during operation
		4 flash	Serial signal (forward) error, at operation start up
		5 flash	Serial signal (forward) error, during operation
Indoor unit thermistor error	2 flash	2 flash	Indoor temperature thermistor open / short
		3 flash	Heat exchanger middle thermistor open / short
Outdoor unit thermistor error	3 flash	2 flash	Discharge thermistor open / short
		3 flash	Heat exchanger thermistor open
		4 flash	Outdoor temperature thermistor open / short
Indoor unit control error	4 flash	2 flash	Forced automatic SW welded
		3 flash	Main relay welded
		4 flash	Power interruption error
Outdoor unit control error	5 flash	2 flash	Current trip error
		3 flash	CT abnormal
		5 flash	Compressor location detection error
		6 flash	Outdoor unit fan drive system abnormal
Indoor fan motor error	6 flash	2 flash	Abnormal lock
		3 flash	Abnormal rotation
Refrigerant cycle error	7 flash	2 flash	Discharge Temperature abnormal
		3 flash	Cooling high pressure abnormal rise
Optional function error	8 flash	2 flash	Active filter abnormal (first time)
		3 flash	Active filter abnormal (second time)
Model error	Blinking	Blinking	Model error

DISASSEMBLY ILLUSTRATION

Models : AWHZ14LBC
AWHZ18LBC

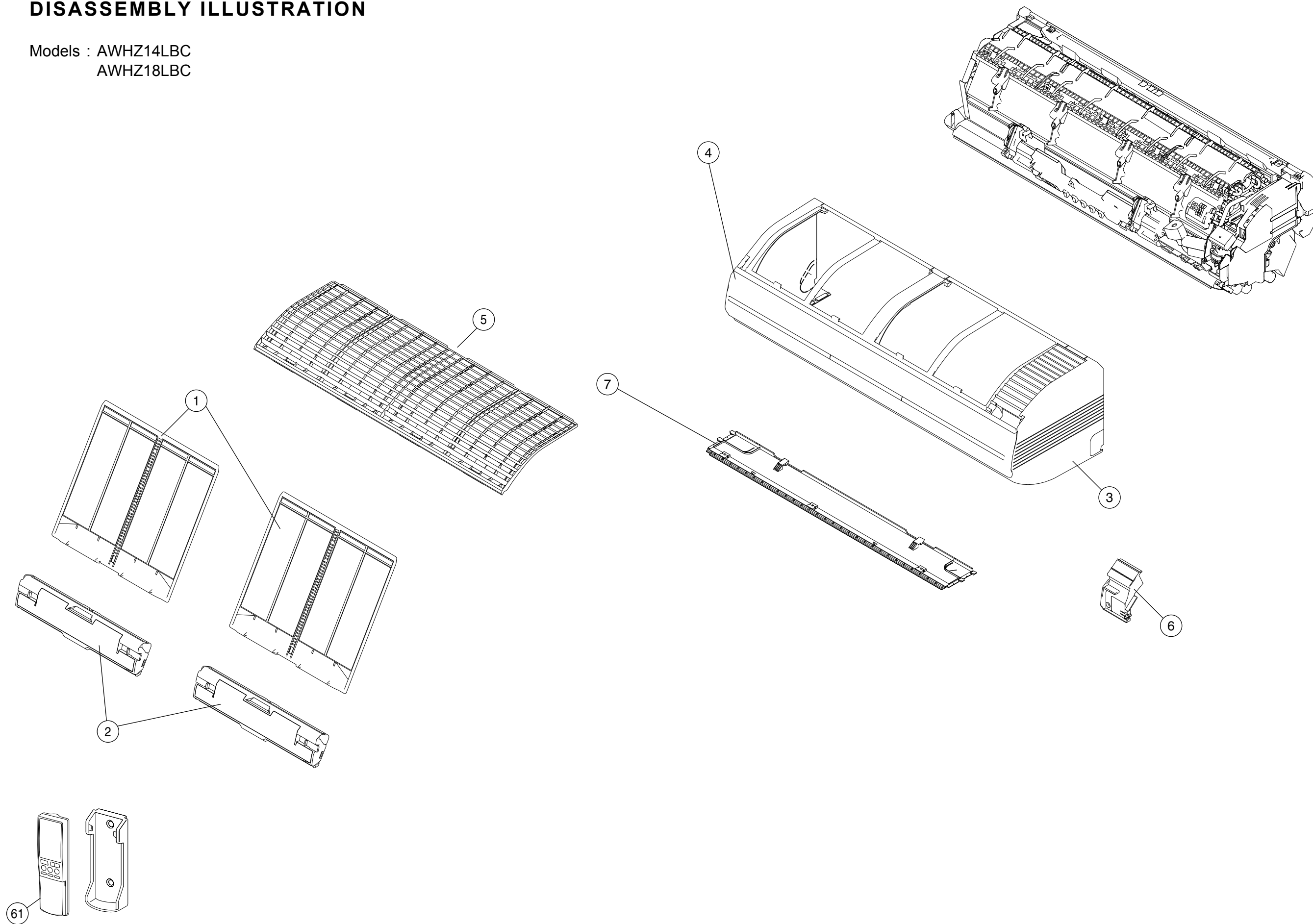

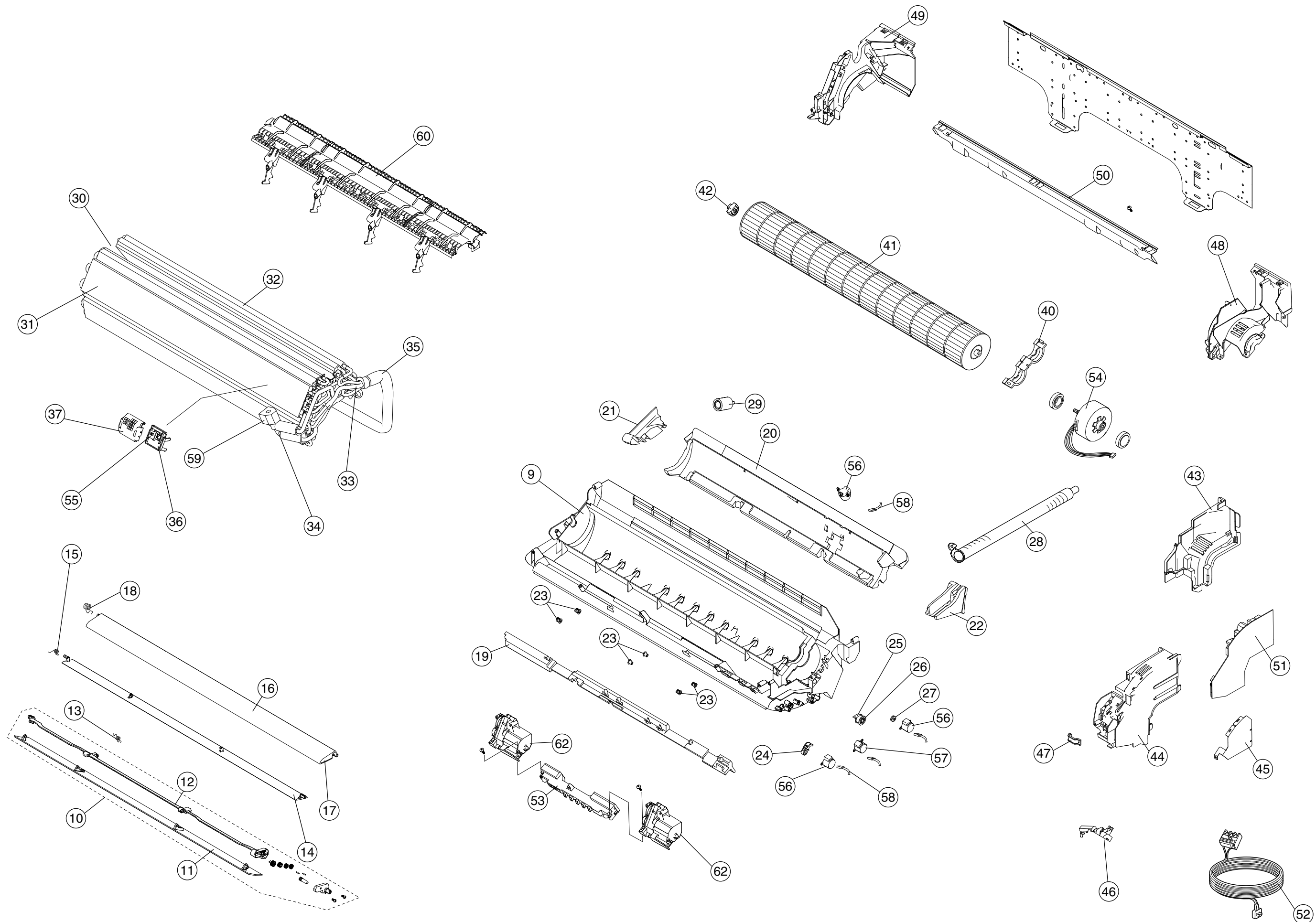

Models : AOHZ14LBC
AOHZ18LBC

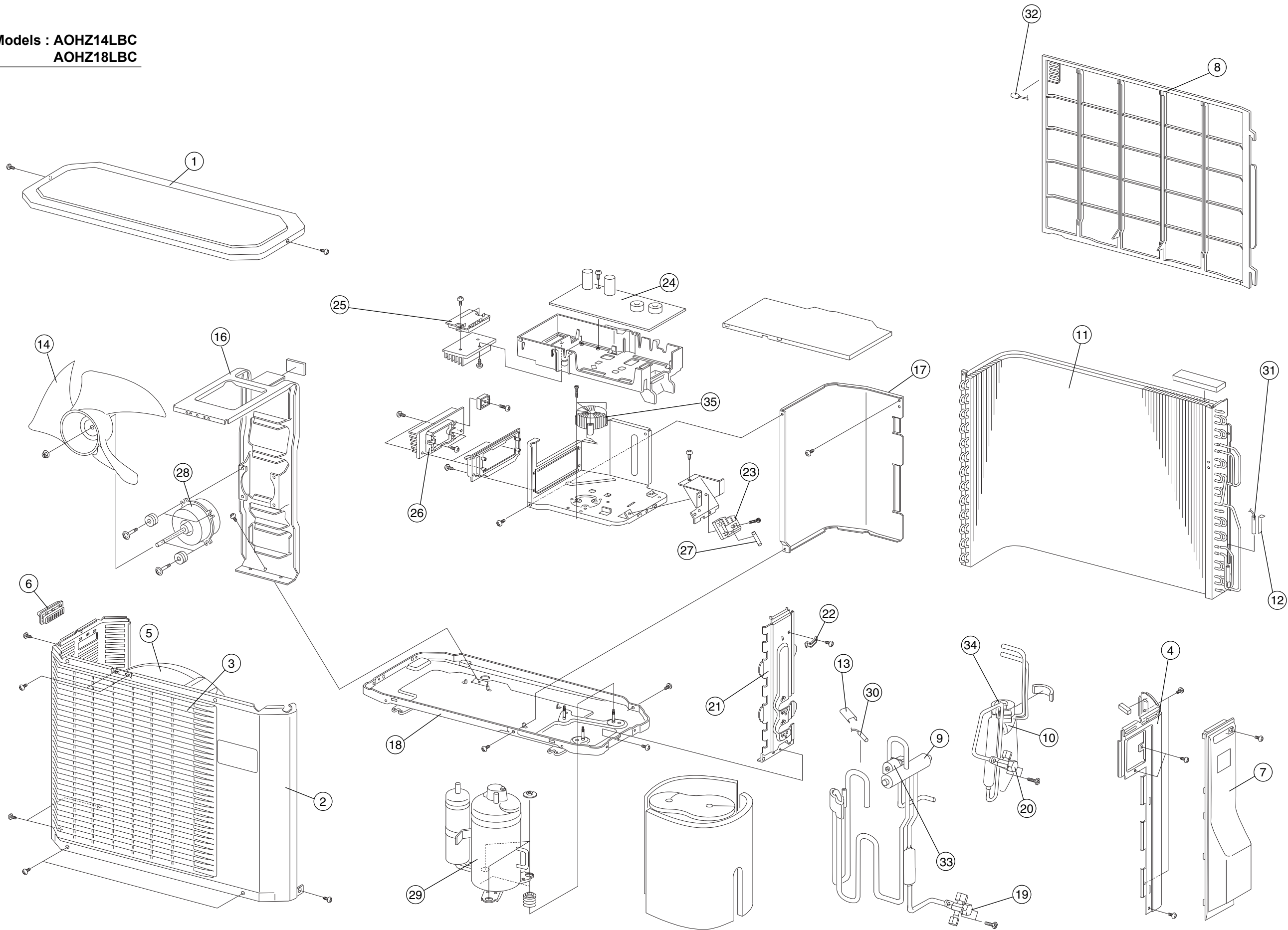

PARTS LIST

INDOOR UNIT





Ref. No.	Description	Part No.		Ord. Q'ty
		AWHZ14LBC	AWHZ18LBC	
1	Air Filter	9313859015	9313859015	
2	Dust Box Assy	9313884024	9313884024	
3	Front Panel Assy	9313882044	9313882044	
4	Open Panel Assy	9314405037	9314405037	
5	Top Grill	9313848019	9313848019	
6	Top Cover	9313849023	9313849023	
7	Under Cover	9313850029	9313850029	
9	Casing Assy	9313877019	9313877019	
10	Louver U Assy	9312243037	9312243037	
11	Louver U	9311993032	9311993032	
12	Louver Frame	9311994015	9311994015	
13	Spring EL	9312194001	9312194001	
14	Louver Z	9311996033	9311996033	
15	Spring F	9314143014	9314143014	
16	Diffuser U	9313856014	9313856014	
17	Diffuser Z	9313857011	9313857011	
18	Spring C	9314142017	9314142017	
19	Casing Cover F	9313839017	9313839017	
20	Casing Cover B	9313838010	9313838010	
21	Casing Cover L	9313887018	9313887018	
22	Casing Cover R	9313888015	9313888015	
23	Bushing-A	9303529010	9303529010	
24	Louver Cam	9312000012	9312000012	
25	Tension A	9312197002	9312197002	
26	Spring Holder	9311999010	9311999010	
27	Gear A	9309994003	9309994003	
28	Drain Hose Assy	9314147012	9314147012	
29	Drain Cap Assy	9304150008	9304150008	
30	Evaporator Assy	9314110016	9314110016	
31	Evaporator Assy B	9312213023	9312213023	
32	Evaporator Assy C	9312465026	9312465026	
33	Joint Pipe Assy	9314111020	9314111020	
36	Sensor Case	9313843014	9313843014	
37	Sensor Cover	9313853013	9313853013	
40	Motor Cover	9313840013	9313840013	
41	Crossflow Fan Assy	9312004010	9312004010	
42	Bearing C Assy	9306628017	9306628017	
43	Control Box	9312005017	9312005017	
44	Controll Cover	9312006014	9312006014	
46	Receiver Case	9313842017	9313842017	
47	Cord Clamp	9302271002	9302271002	
48	Evaporator Holder R	9313833015	9313833015	
49	Evaporator Holder L	9313834012	9313834012	
50	Rear Bracket	9312416011	9312416011	
51	Controller PCB Assy	9707170016	9707170023	
52	Power Cord Assy	9900339029	9900339029	
53	Display Assy	9705808027	9705808027	
54	Fan Motor Assy	9601888017	9601888017	
56	Stepping Motor U	9703477010	9703477010	
57	Stepping Motor Z	9305780006	9305780006	
58	Connector w/Wire S	9314144011	9314144011	
60	UV Unit Assy	9314153013	9314153013	
61	Remote Controller Assy	9314157035	9314157035	
62	Gear Box Assy	9313880019	9313880019	
---	Room Temp. Thermistor	9700801139	9700801139	
---	Pipe Temp. Thermistor	9702039042	9702039042	
---	Fuse 3A	0600376062	0600376062	
---	Relay	9704185013	9704185013	

OUTDOOR UNIT

Ref. No.	Description	Part No.		Ord. Q'ty
		AOHZ14LBC	AOHZ18LBC	
1	Top Panel Assy	9309230057	9309230057	
2	Cabinet Sub Assy	9314809040	9314809040	
3	Blow Grill	9308884015	9308884015	
4	Cabinet Right Assy	9309236011	9309236011	
5	Fan Ring	9308885012	9308885012	
6	Grip	9308880017	9308880017	
7	Switch Cover Assy	9309237025	9309237025	
8	Protective Net	9315319012	9315319012	
9	4-way Valve	9970036019	9970036019	
10	Pulse Motor Valve Assy	9314444012	9314444012	
11	Condenser Assy	9314040023	9314040023	
12	Thermo Spring A	313728262708	313728262708	
13	Thermo Spring	9300089012	9300089012	
14	Propeller Fan	9309909014	9309909014	
16	Motor Bracket	9308872012	9308872012	
17	Separater	9312032020	9312032020	
18	Base Assy	9308869081	9308869081	
19	3-way Valve Assy	9315159014	9315159014	
20	2-way Valve Assy	9313062019	9313062019	
21	Valve Bracket	9308870025	9308870025	
22	Cord Clamp	9307271014	9307271014	
23	Terminal 3P	9306489038	9306489038	
24	Inverter PCB Assy	9707132014	9707132021	
25	TR PCB Assy	9705753013	9705753013	
26	ACTPM	9703457012	9703457012	
27	Fuse	0600086190	0600086190	
28	Fan Motor	9601815013	9601815013	
29	Compressor Assy	9314061011	9314061011	
30	Discharge Thermistor	9704219091	9704219091	
31	Heat Exchange Thermistor	9704220028	9704220028	
32	Outdoor Temp. thermistor	9703516092	9703516092	
33	Solenoid	9970055010	9970055010	
34	Expansion Valve Coil	9900057039	9900057039	
35	Choke coil	9703458019	9703458019	
---	Emblem	9315211019	9315211019	
---	Discharge Pipe Assy	9315283016	9315283016	

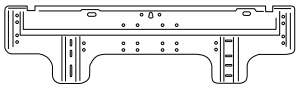
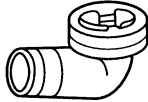
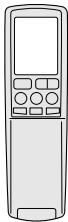
STANDARD ACCESSORIES

The following installation accessories are supplied.
Use them as required.

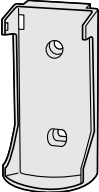
Name and Shape	Q'ty	Name and Shape	Q'ty
Wall hook bracket  9312011018	1	Drain pipe  9303029022	1
Remote control unit  9314157035	1	Cloth tape  9308117007	1
		Tapping screw (big)  0700076046	8
Battery  0600185046	2	Tapping screw (small)  0700019036	2
		Remote control unit holder  9312947010	1



Большая библиотека технической документации
<https://splitsystema48.ru/instrukcii-po-ekspluatacii-kondicionerov.html>
каталоги, инструкции, сервисные мануалы, схемы.